



AIR CONDITIONING



REFRIGERATION



HEATING



mini blanc

CONDENSATE REMOVAL PUMP

The 'ultra quick fit' Mini Blanc is designed to be fitted beneath high wall indoor units and offers easy access for future maintenance.



12L/h max. flow



10m max. rec. head (flow rate 4L/h)



21dB(A)

KEY FEATURES

- Extra quick to fit
- Compact & discreet
- Clear removable reservoir
- Ultra quiet operation

SUITABILITY

- Up to 16kW / 54,000Btu/h
- High wall mini split systems
- ✓ **Perfect for...** Domestic use – where easy maintenance is key

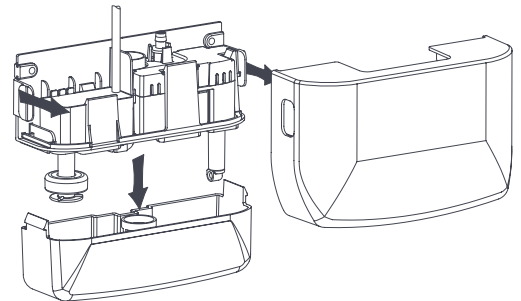
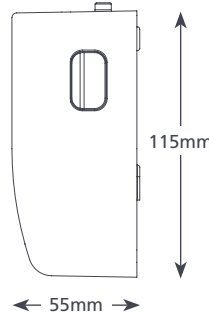
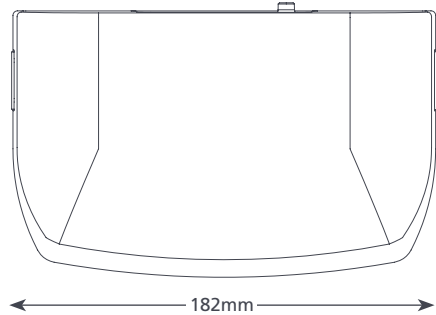

MINI BLANC SPECIFICATIONS

Max. flow	12L/h @ 0 head
Max. rec. head	10m
Max. suction lift	n/a
Sound level@1m	21dB(A)
Power supply	230V AC 50-60Hz 0.1A*
Rated	Non continuous
Class	II appliance <input type="checkbox"/>
Max. unit output	16kW / 54,000Btu/h
Max. water temp	40°C / 104°F
Inlet/outlet	6mm in, 6mm out
IP Protection	IPX1
Safety switch	3.0A Normally closed
Thermal protection	✓
Fully potted	✓
Self priming	✓

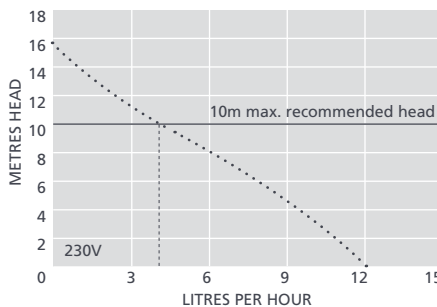

SUGGESTED XTRA ACCESSORIES

Description	Part No.
1 Amp Fuse	FP2620
Tube To Soil Stack Adaptor	FP2038
Mini Blanc Ivory Cover	FP1037

Xtra For more installation accessories take a look at our Aspen Xtra range

MINI BLANC OPTIONS

Mini Blanc FP1080

*Other voltages available

IN THE BOX

Mini Blanc pump (including hard wired 1.5m power cable) • Anti siphon device • Drain connector kit • Fixing kit • Install manual

Download manual at aspenspumps.com

View install video at aspenspumps.com



aspenspumps.com

+44 (0)1323 848842

sales@aspenspumps.com

Making life easier for the installer