



AIR CONDITIONING



REFRIGERATION



HEATING



silent+ MINI AQUA

CONDENSATE REMOVAL PUMP

Combining Silent+ technology and the slimmest mini pump on the market, the Silent+ Mini Aqua leads the way in innovation.

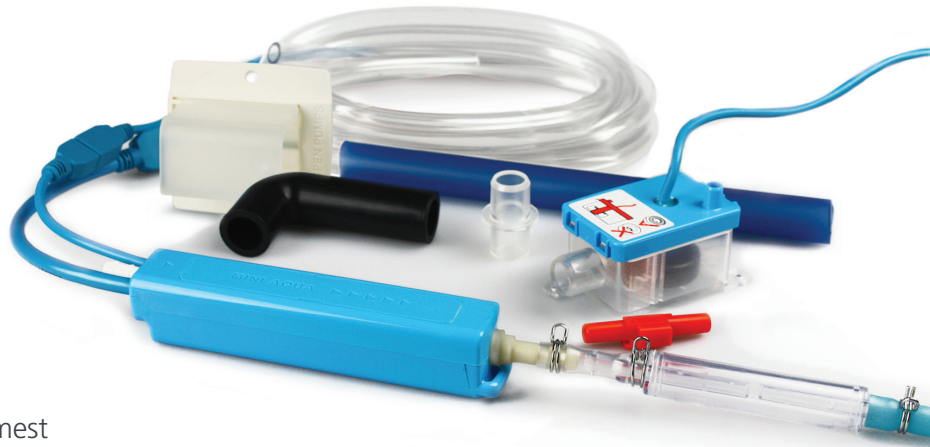

12L/h max. flow



10m max. rec. head
(flow rate 6L/h)



19dB(A)

KEY FEATURES

- Quietest in its class
- Acoustic damper
- Plug & play
- Anti siphon device

SUITABILITY

- Up to 16kW / 54,000Btu/h
 - Ducted units; Floor standing & Chassis units; High wall mini split systems
- ✓ **Perfect for...** Small & quiet – you'll never know it's there!



0.18[†]
kg

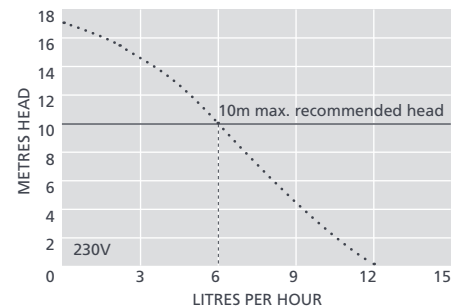
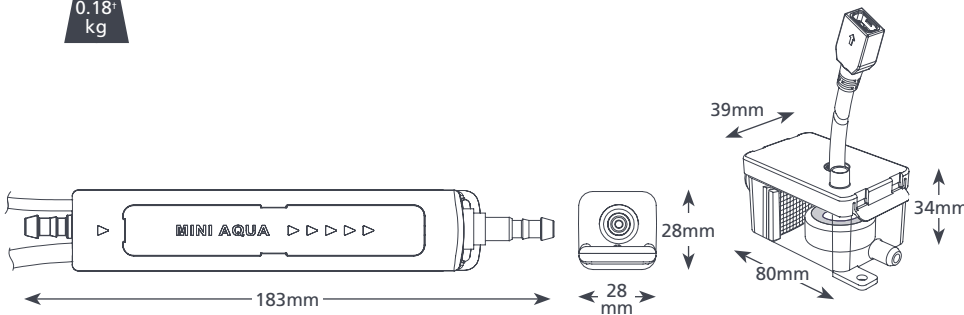

SILENT+ MINI AQUA SPECIFICATIONS

Max. flow	12L/h @ 0 head
Max. rec. head	10m
Max. suction lift	2m
Sound level@1m	19dB(A)
Power supply	230V AC 50-60Hz 0.1A*
Rated	Non continuous
Class	II appliance <input type="checkbox"/>
Max. unit output	16kW / 54,000Btu/h
Max. water temp	40°C / 104°F
Discharge tube	6mm ID
IP Protection	IPX4
Safety switch	3.0A Normally closed
Thermal protection	✓
Fully potted	✓
Self priming	✓

SILENT+ MINI AQUA OPTIONS

Silent+ Mini Aqua	FP3326
-------------------	--------

* Other voltages available
† Pump only

SUGGESTED XTRA ACCESSORIES

Description	Part No.
1 Amp Fuse	FP2620
Tube To Soil Stack Adaptor	FP2038
Vinyl Tube Braided 1/4" (6mm)	AX5100
Inline Filter 16mm	FP2640

Xtra For more installation accessories take a look at our Aspen Xtra range

IN THE BOX

- Silent+ Mini Aqua pump
- Reservoir (inc. filter, float, lid)
- 1.5m Plug & play power cable
- Acoustic damper and 1m aqua discharge tube with connector
- Anti vibration bracket
- 150mm Vinyl breather tube 6mm ID
- Anti siphon device
- 1.5m Suction breather tube 6mm ID
- 220mm Blue inlet hose 14mm ID
- Drain connector kit
- Fixing kit
- Install manual

- 📖 Download manual at aspenpumps.com
- ▶ View install video at aspenpumps.com